

Name _____

Date _____

Period _____

Energy Free Response - (18 pts)

1 _____

2 _____

3 _____

4 _____

5 _____

6

7

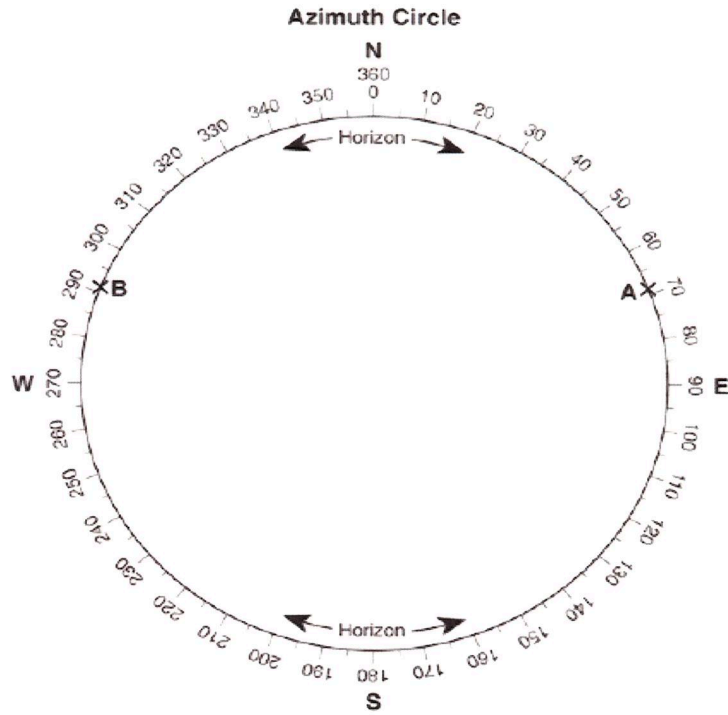
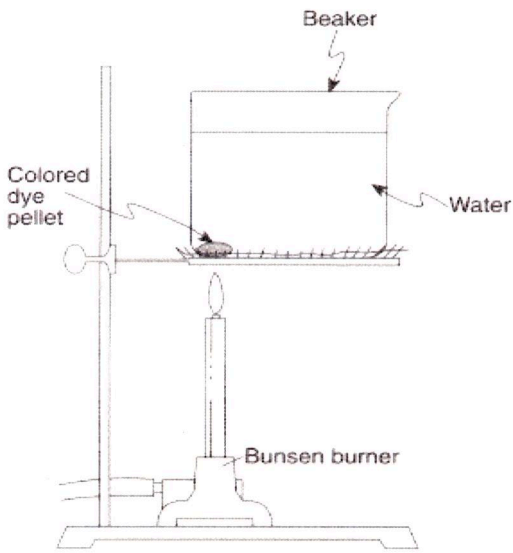

8 _____

9 _____

10

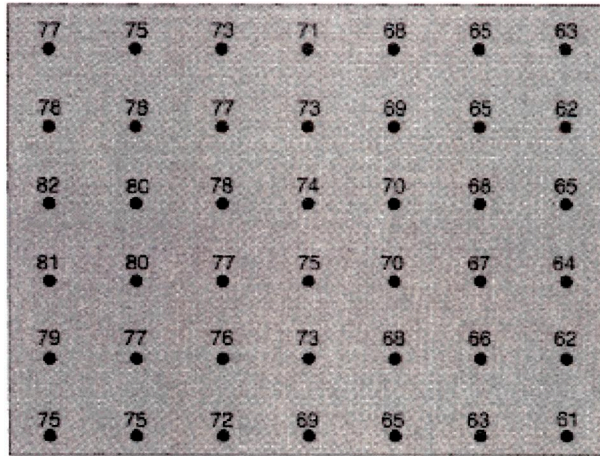

On the field map above, draw the 70°F and 80°F isotherms. The isotherms should be extended to the edges of the map.

11

&

13

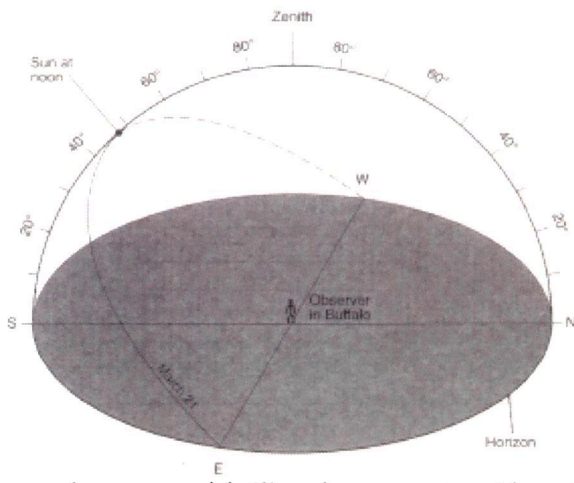

12

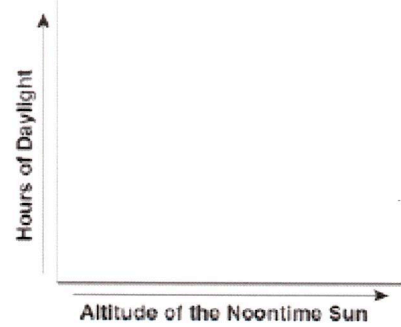

14

15

16

17

18

Duration of Insolation at Barrow, Alaska

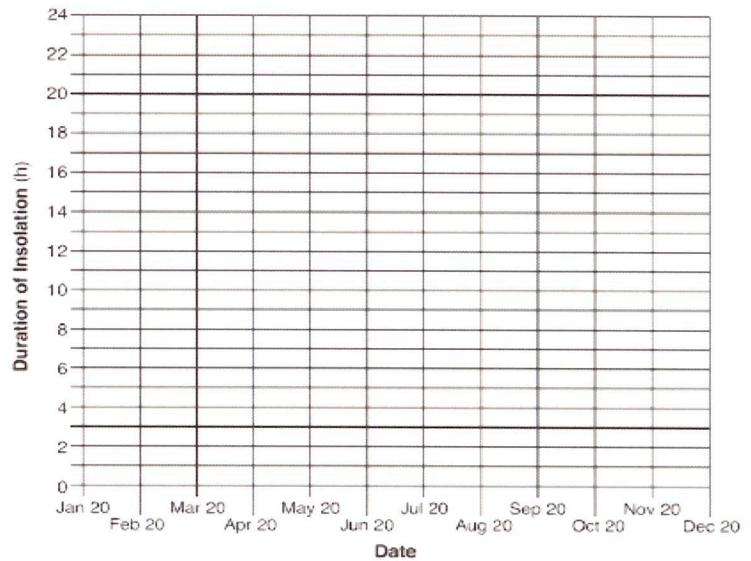

Base your answers to questions 1 through 3 on the passage below.

Ozone in Earth's Atmosphere

Ozone is a special form of oxygen. Unlike the oxygen we breathe, which is composed of two atoms of oxygen, ozone is composed of three atoms of oxygen. A concentrated ozone layer between 10 and 30 miles above Earth's surface absorbs some of the harmful ultraviolet radiation coming from the Sun. The amount of ultraviolet light reaching Earth's surface is directly related to the angle of incoming solar radiation. The greater the Sun's angle of insolation, the greater the amount of ultraviolet light that reaches Earth's surface. If the ozone layer were completely destroyed, the ultraviolet light reaching Earth's surface would most likely increase human health problems, such as skin cancer and eye damage.

1. Assuming clear atmospheric conditions, on what day of the year do people in New York State most likely receive the most ultraviolet radiation from the Sun?
2. Explain how the concentrated ozone layer above Earth's surface is beneficial to humans.
3. State the name of the temperature zone of Earth's atmosphere where the concentrated layer of ozone gas exists.

Base your answers to questions 4 and 5 on the diagram below, which shows incoming solar radiation passing through the glass of a greenhouse and then striking the floor.

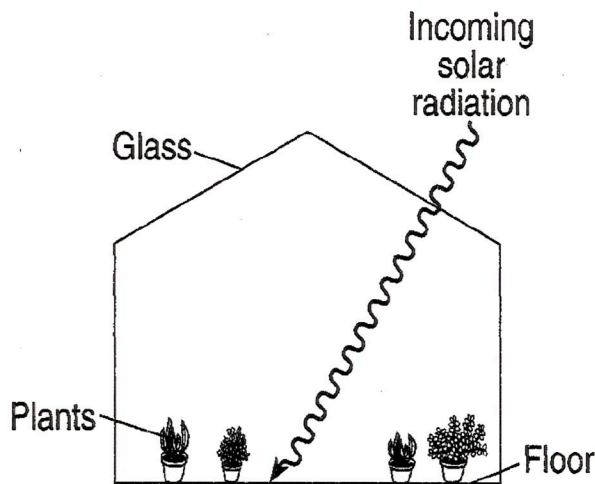

4. Describe *one* way the glass in the greenhouse acts like the greenhouse gases in Earth's atmosphere.
 5. Some of the incoming solar radiation is absorbed by the floor. Identify the type of electromagnetic energy reradiated by the floor.
- _____

6. The diagram below represents a beaker of water that is being heated. As the colored dye pellet dissolves, the dye will show the movement of water in the beaker. On the diagram, draw arrows in the water to show the direction the colored dye will move when the water is heated as shown.

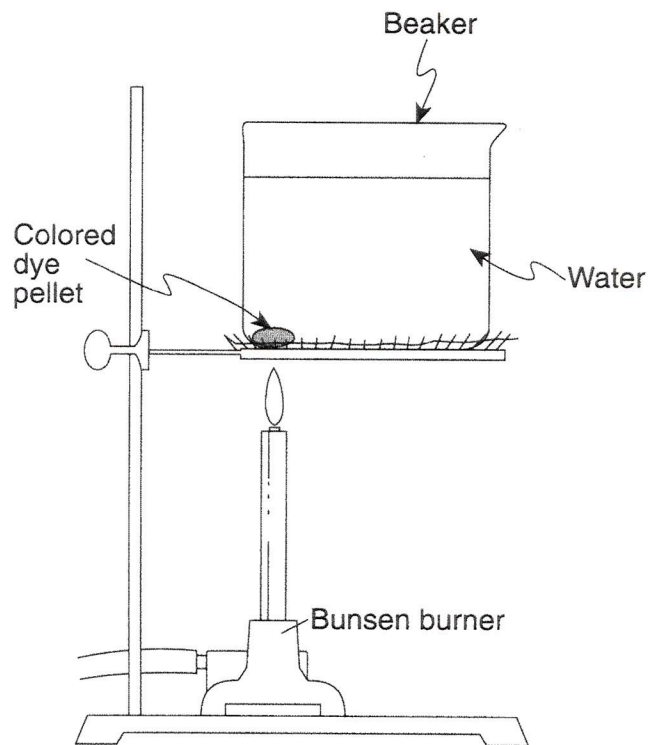

Energy Free Response

Base your answers to questions 7 and 8 on the data table below, which shows the azimuths of sunrise and sunset on August 2 observed at four different latitudes. Azimuth is the compass direction measured, in degrees, along the horizon, starting from north.

Data Table

Latitude	Azimuths of Sunrise and Sunset	Letter Code
30° N	sunrise 69°	A
	sunset 291°	B
40° N	sunrise 66°	C
	sunset 294°	D
50° N	sunrise 61°	E
	sunset 299°	F
60° N	sunrise 51°	G
	sunset 309°	H

7. On the outer edge of the azimuth circle below, mark with an **X** the positions of sunrise and sunset for *each* latitude shown in the data table. Write the correct letter code beside each **X**. The positions of sunrise and sunset for 30° N have been plotted and labeled with letters *A* and *B*.

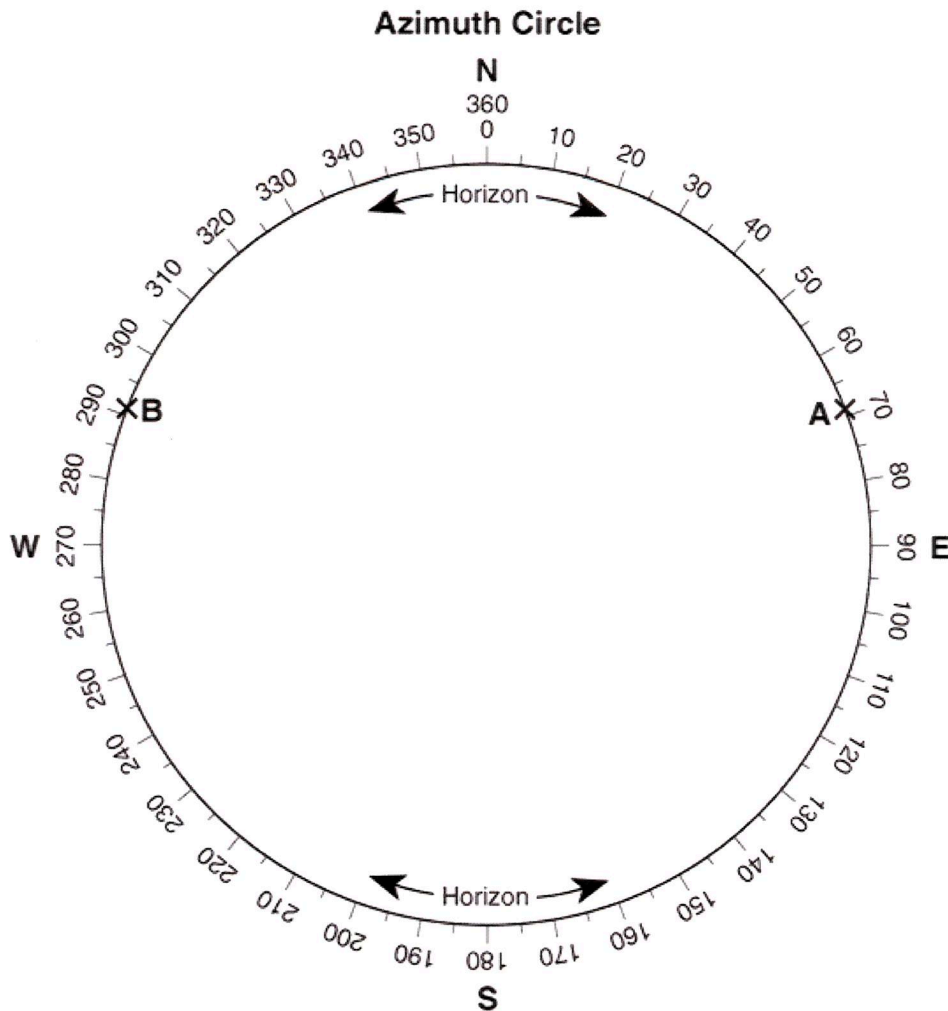

8. State the relationship at *sunrise* between the latitude and the azimuth.

Energy Free Response

9. Base your answer to the following question on the field map below. The field map shows temperatures, in degrees Fahrenheit, taken at several locations on a blacktop parking lot in New York State. The temperatures were recorded at 11:00 a.m. in early June.

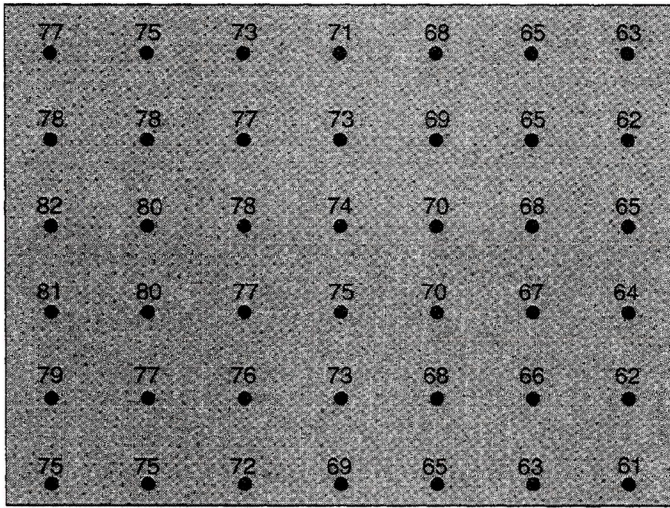

(10)

On the field map above, draw the 70°F and 80°F isotherms.

The isotherms should be extended to the edges of the map.

- 9) Explain why the surface of this parking lot usually becomes warmer from 11:00 a.m. to 12 noon each day.

Base your answers to questions 11 through 13 on the data table below. A student recorded the hours of daylight and the altitude of the Sun at noon on the twenty-first day of every month for one year in Buffalo, New York.

Data Table

Date	Hours of Daylight	Altitude of the Sun at Noon (°)
January 21	9.5	32.3
February 21	10.8	40.1
March 21	12.0	47.3
April 21	13.7	55.1
May 21	14.8	62.5
June 21	15.3	70.4
July 21	14.8	63.3
August 21	13.7	55.5
September 21	12.1	47.7
October 21	10.8	39.9
November 21	9.5	32.1
December 21	9.0	24.4

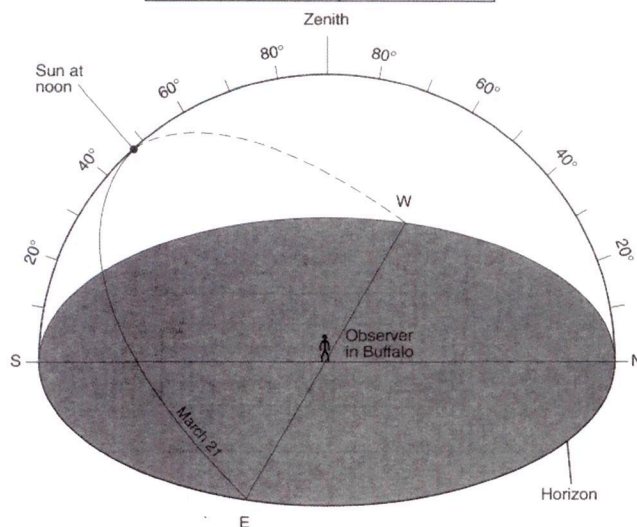

- 11) On the same sky model above, place an asterisk (*) at the apparent position of the North Star as seen from Buffalo.

Energy Free Response

12. On the graph below, draw a line to represent the general relationship between the altitude of the Sun at noon and the number of hours of daylight throughout the year at Buffalo.

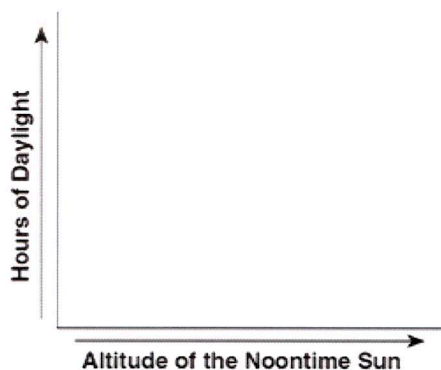

13. The sky model diagram above shows the apparent path of the Sun on March 21 for an observer in Buffalo, New York. Draw a line to represent the apparent path of the Sun from sunrise to sunset at Buffalo on May 21. Be sure your path indicates the correct altitude of the noon Sun and begins and ends at the correct positions on the horizon.

Base your answers to questions 14 through 16 on the diagram below, which shows Earth as seen from above the North Pole. The curved arrows show the direction of Earth's motion. The shaded portion represents the nighttime side of Earth. Some of the latitude and longitude lines have been labeled. Points A and B represent locations on Earth's surface.

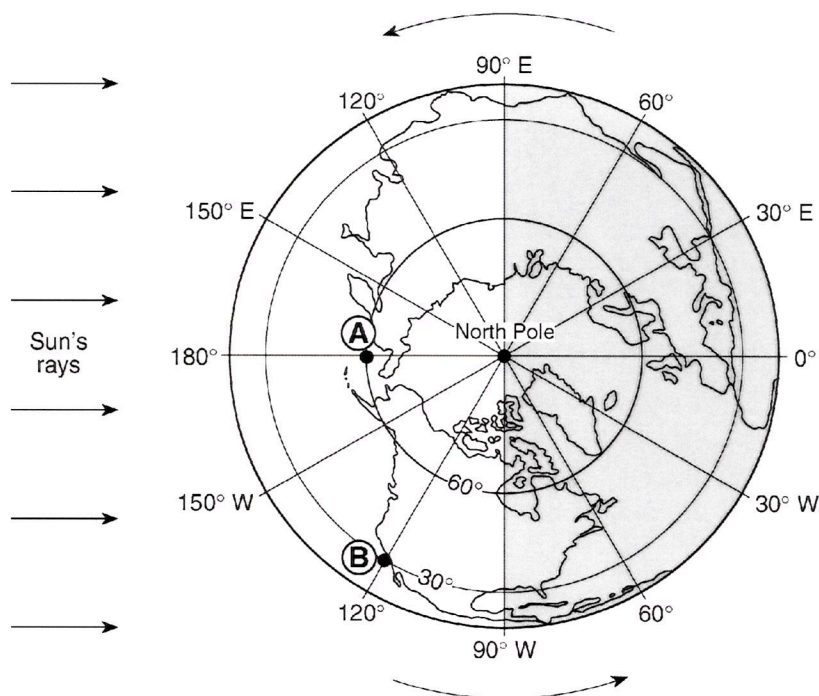

14. Identify *one* possible date that is represented by the diagram.
15. Explain why the angle of insolation at solar noon is greater at point B than at point A.
16. If it is 4:00 p.m. at point B, what is the time at point A?

Energy Free Response

Base your answers to questions 17 and 18 on

the table and map below. The table shows the duration of insolation, in hours, at Barrow, Alaska, on the twentieth day of each month during 2008. The map shows the location of Barrow at $71^\circ \text{ N } 156.5^\circ \text{ W}$.

**Duration of Insolation
at Barrow, Alaska**

Date	Duration of Insolation (h)
Jan 20	0
Feb 20	7.8
Mar 20	12.5
Apr 20	17.6
May 20	24
June 20	24
July 20	24
Aug 20	16.7
Sept 20	12.6
Oct 20	7.8
Nov 20	0
Dec 20	0

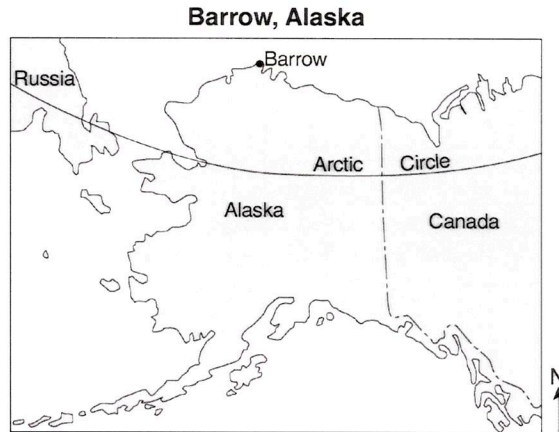

17. On the grid below, construct a line graph by plotting the data for the duration of insolation at Barrow for *each* date shown on the data table. Connect the plots with a line.

Duration of Insolation at Barrow, Alaska

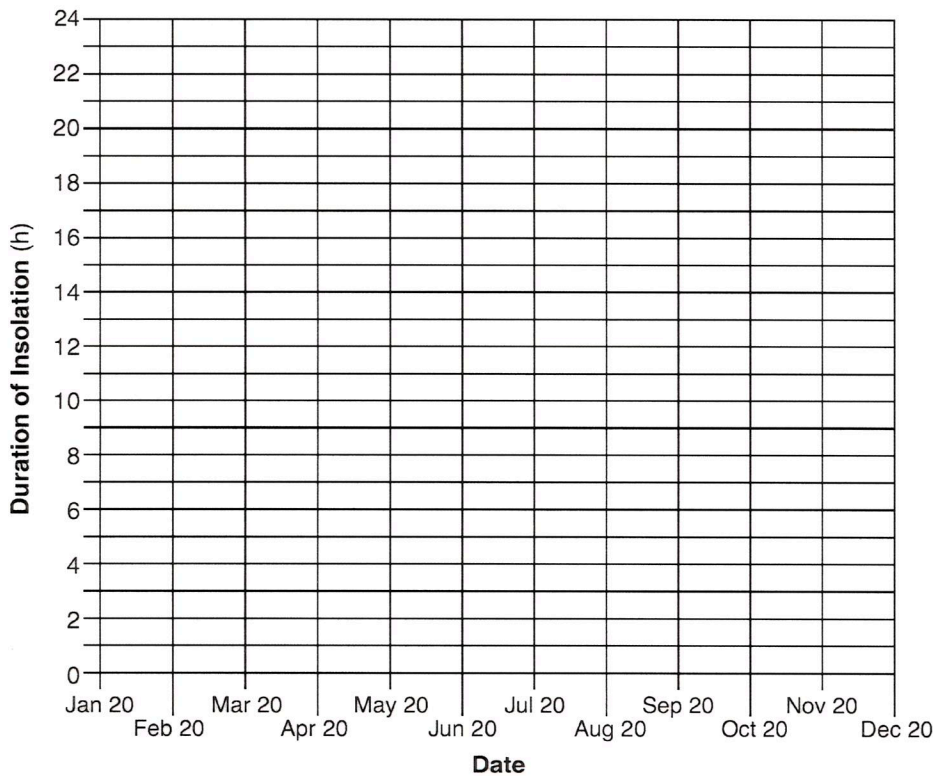

18. Explain why Barrow receives 0 hours of insolation on December 20.

ESRT - Energy Charts

Specific Heats of Common Materials

MATERIAL	SPECIFIC HEAT (Joules/gram • °C)
Liquid water	4.18
Solid water (ice)	2.11
Water vapor	2.00
Dry air	1.01
Basalt	0.84
Granite	0.79
Iron	0.45
Copper	0.38
Lead	0.13

Equations

$$\text{Eccentricity} = \frac{\text{distance between foci}}{\text{length of major axis}}$$

$$\text{Gradient} = \frac{\text{change in field value}}{\text{distance}}$$

$$\text{Rate of change} = \frac{\text{change in value}}{\text{time}}$$

$$\text{Density} = \frac{\text{mass}}{\text{volume}}$$

Properties of Water

Heat energy gained during melting 334 J/g
Heat energy released during freezing 334 J/g
Heat energy gained during vaporization 2260 J/g
Heat energy released during condensation	... 2260 J/g
Density at 3.98°C 1.0 g/mL

Electromagnetic Spectrum

